

SD-SM SERIES

HIGH VOLTAGE STEPPING MOTORS 34 frame size

The SM series motors have exceptionally high torque and are suited to, high speed applications using high voltage drives. Some of models are compatible the new high voltage RTA, X-MIND-B6 drive. The standard NEMA 34 flange is still used so mounting holes are the same as standard stepper motors. Motor shaft is larger to handle higher torque.

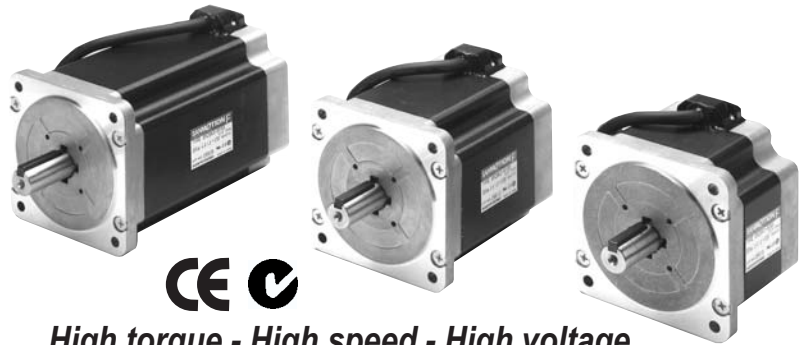

SPECIFICATIONS

MODEL NUMBER	No. Shafts	No. Stacks	Motor Length (mm)	Phase Current (Amp)	Phase Resistance (Ω)	Phase Inductance (mH)	Holding Torque (Nm)	Rotor Inertia (kg.mm ²)	Voltage Constant (V/krpm)	Motor Mass (kg)
SM2861-5055	1	1	66	2.0	2.2	15.0	3.6	148	180	1.7
SM2861-5255	1	1	66	6.0	0.29	1.7	3.6	148	60	1.7
SM2861-5225	2									
SM2862-5055	1	2	96.5	2.0	3.2	25	7.0	300	350	2.9
SM2862-5155	1	2	96.5	4.0	0.83	6.4	7.0	300	175	2.9
SM2862-5125	2									
SM-2862-5255	1	2	96.5	6.0	0.36	2.8	7.0	300	120	2.9
SM-2862-5225	2									
SM2863-5155	1	3	127	4.0	1.0	7.9	9.2	450	241	4.0
SM2863-5125	2									
SM2863-5255	1	3	127	6.0	0.46	3.8	9.2	450	161	4.0
SM2863-5225	2									

DIMENSIONS

(in mm)

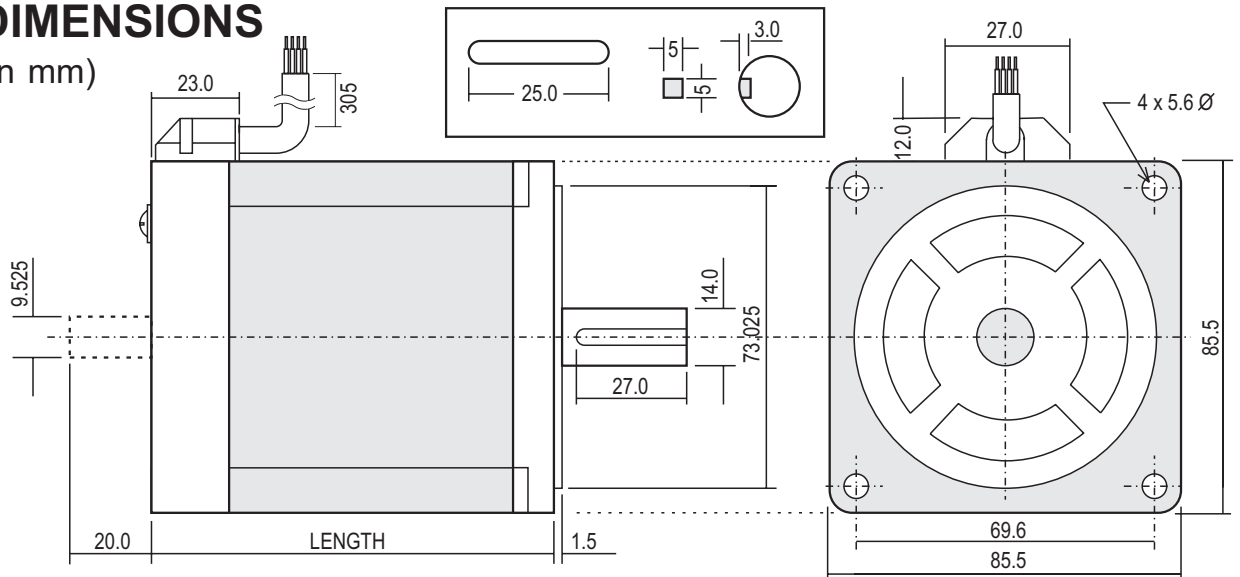

SDSM34FT

DRIVE CONNECTIONS

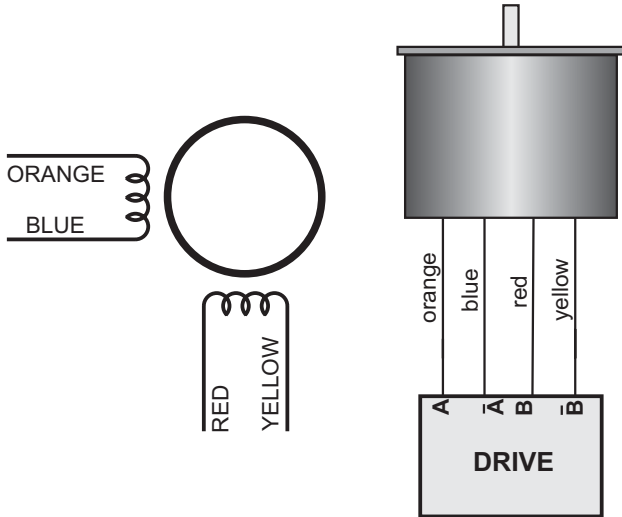

NOTES

STANDARDS

UL, CE, RoHS

INSULATION VOLTAGE

250 VAC (350 VDC)

PROTECTION

Environmental protection IP43

CONSTRUCTION

200 steps/rev, 2 phase

CONNECTION

4 wire, parallel (series & unipolar not possible)

FLANGE

NEMA 34

TORQUE CURVES

Drives set to half step mode
(400 step/rev).

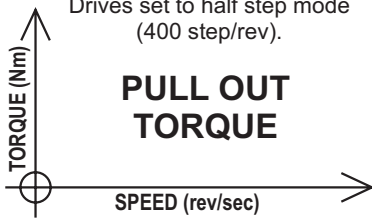

SM2861-5255 & 75V drive

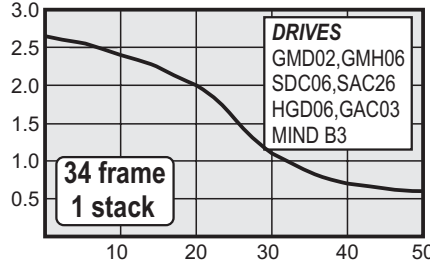

SM2861-5255 & 130V drive

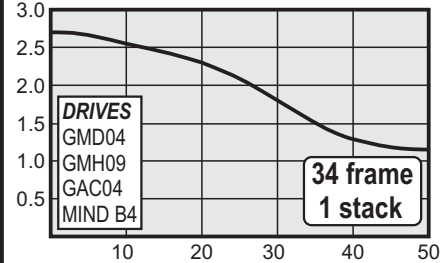

SM2861-5255 & 180V drive

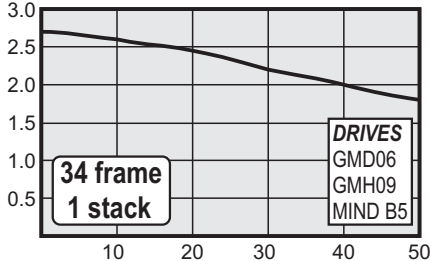

SM2862-5255 & 75V drive

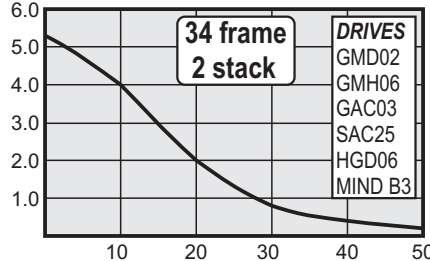

SM2862-5255 & 130V drive

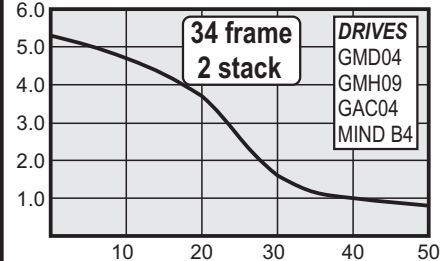

SM2862-5255 & 180V drive

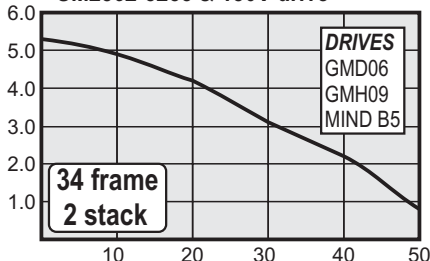

SM2862-5255 & 325V drive

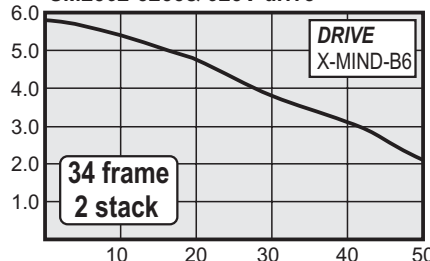

SM2863-5255 & 75V drive

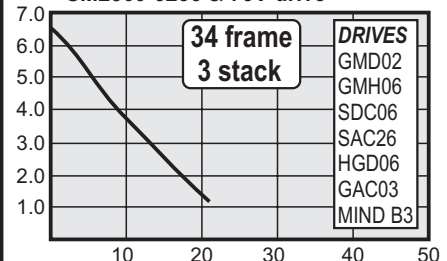

SM2863-5255 & 130V drive

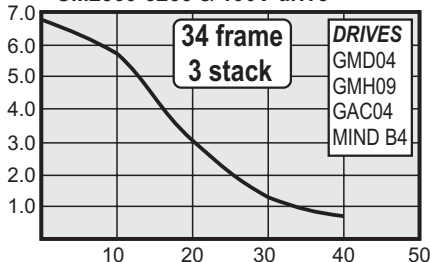

SM2863-5255 & 180V drive

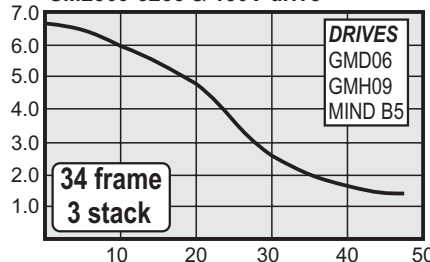

SM2863-5255 & 325V drive

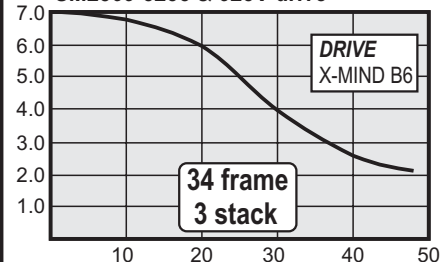

AUTOMATED MOTION SYSTEMS PTY.LTD.

MAILING ADDRESS:
P.O.BOX 1240
WANGARA DC
W.A. 6947

PHONE: (08) 9309 1896
FAX: (08) 9309 5671
EMAIL: sales@automotsys.com.au
INTERNET: <http://www.automotsys.com.au>

OFFICE ADDRESS:
UNIT2, 7 BARETTA RD.
WANGARA, PERTH
WESTERN AUSTRALIA