

SD-H SERIES

HIGH PERFORMANCE STEPPING MOTORS

42 frame size

Sometimes, a standard stepper motor has insufficient torque or safety margin to drive a machine. This may be the result of higher than expected inertia or friction. Sometimes the motor can be replaced with the next stack size but this is not always possible. The 'H' series high performance motors with much higher torque, higher efficiency, lower noise and vibration solve this problem. The standard NEMA flange is still used so mounting holes are the same (except for larger shaft to handle higher torque). Torque is improved and motor inertia is higher so they are better able to handle high loads.

High torque



SPECIFICATIONS

MODEL NUMBER	No. Shafts	No. Stacks	Motor Length (mm)	Phase Current (Amp)	Phase Resistance (Ω)	Phase Inductance (mH)	Holding Torque (Nm)	Rotor Inertia (kg.mm ²)	Voltage Constant (V/krpm)	Motor Mass (kg)
103-H89222-6541	1	2	163	10.0	0.16	1.9	16.2	1465	162	7.0
103-H89223-6641	1	3	221	12.0	0.16	2.0	24.6	2200	205	10.0
103-H89223-6611	2									
103-H89222-6341	1	2	163	6.0	0.45	5.4	16.2	1465	270	7.0
103-H89223-6341	1	3	221	6.0	0.63	8.0	24.6	2200	410	10.0

DIMENSIONS (in mm)

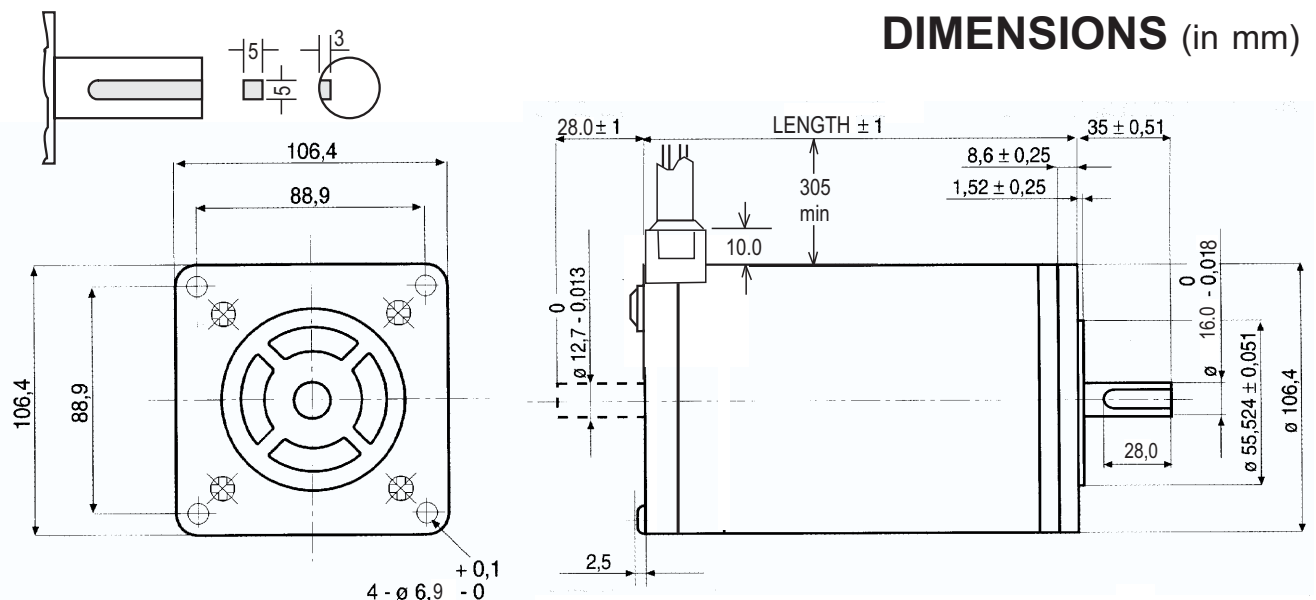

SDH42FT

DRIVE CONNECTIONS

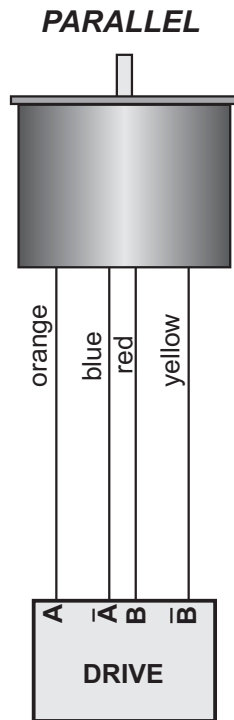

MOTOR CABLES

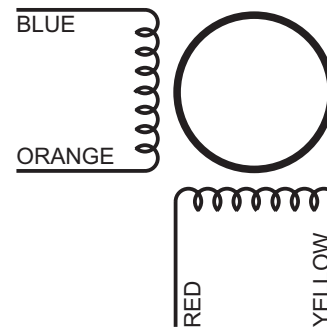

NOTES

MOTOR

Twp phase, hybrid, 200 step/rev.

HOLDING TORQUE

Holding torque is measured for both phases on, motor connected in parallel and drive set to rated motor current.

PROTECTION

Environmental protection IP43

CONNECTION

Because these motors have only four wires, parallel connection is the only alternative.

TORQUE CURVES

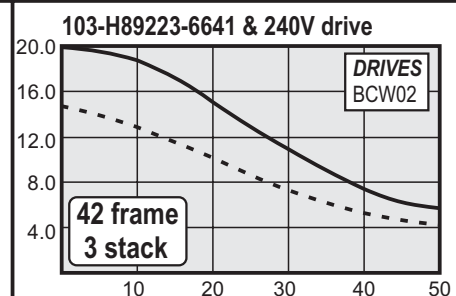
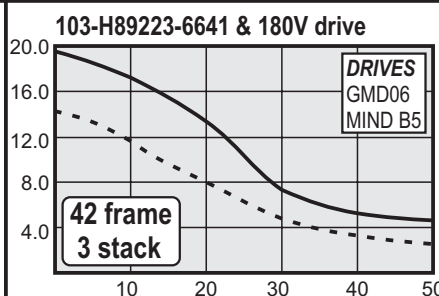
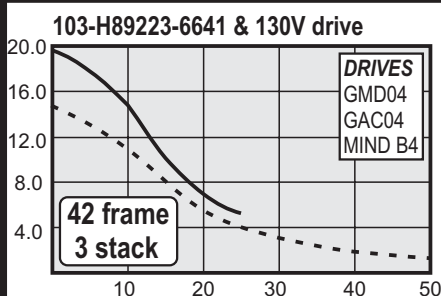
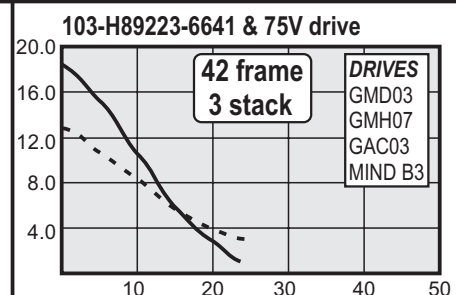
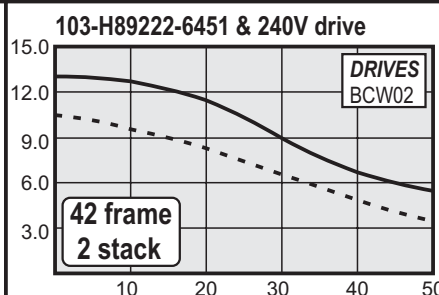
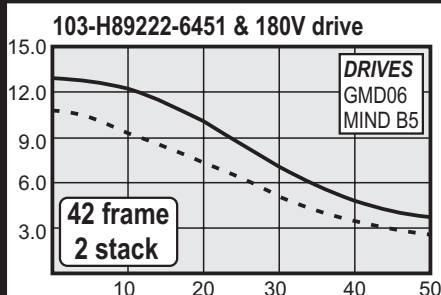
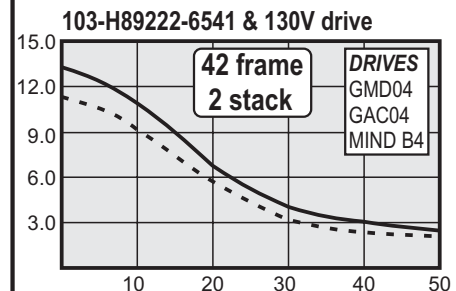
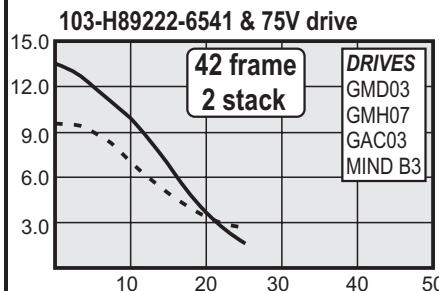
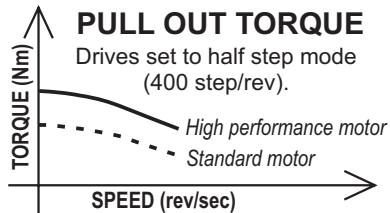

AUTOMATED MOTION SYSTEMS PTY.LTD.

MAILING ADDRESS:
P.O.BOX 1240
WANGARA DC
W.A. 6947

PHONE: (08) 9309 1896
FAX: (08) 9309 5671
EMAIL: sales@automotsys.com.au
INTERNET: <http://www.automotsys.com.au>

OFFICE ADDRESS:
UNIT2, 7 BARETTA RD.
WANGARA, PERTH
WESTERN AUSTRALIA